

CAD FILE:

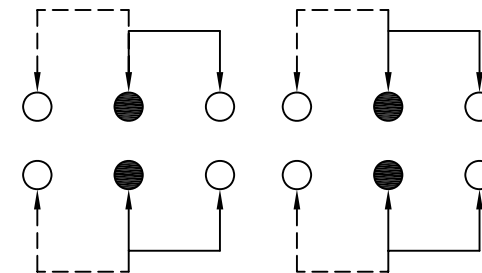

SCHEMATIC (NON-SHORTING)

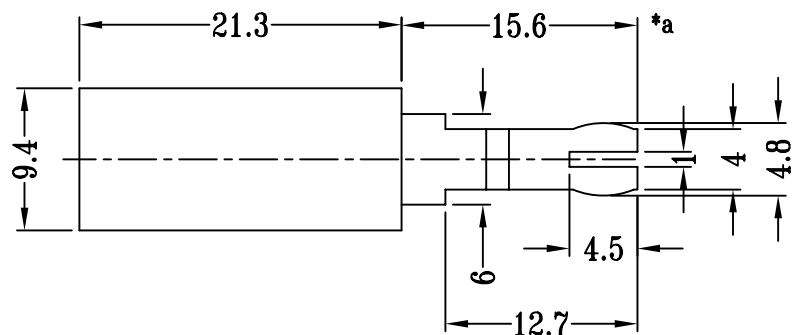
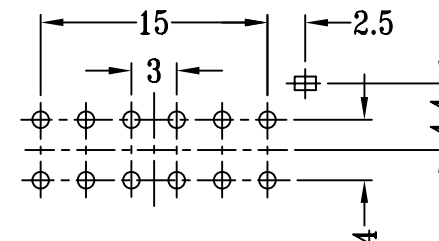
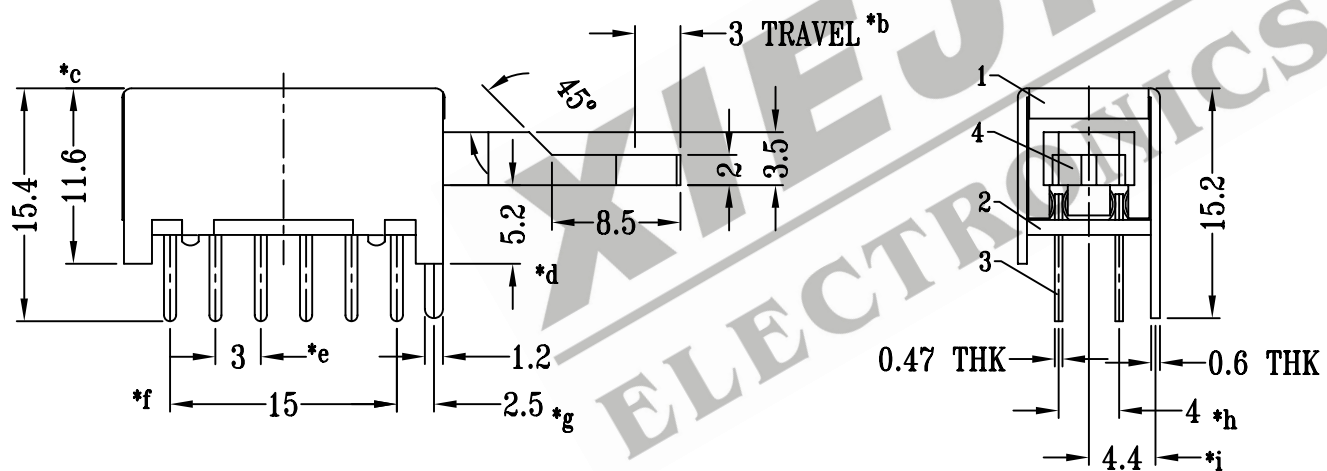

P.C.B LAYOUT

注:带"\*"表示关键尺寸(9个)

8					TOLERANCE UNLESS SPECIFIED	SHENZHEN XIEJIA ELECTRONICS CO.,LTD.				
7										
6	SPRING	STEEL WIRE	1	TEMPER	WITHIN: 1.5±0.1mm OVER: 1.5±0.2mm	ISSUE	DATE	DESCRIPTIONS OF REVISION		APPD.
5	CONTACT CLIP	PBS STRIP	4	Ag PLATED						
4	KNOB	ABS	1	BLACK	TITLE : PUSH SWITCH	UNIT : mm	DRWG NO.: XJ-DR-PS42F11-00			
3	TERMINAL	BRASS STRIP	12	Ag PLATED OVER Ni PLATED						
2	BASE	PHENOLIC RESIN	1	NATURAL	MODEL: PS-42F11	SCALE: 2:1	DWN.	ZHOUYU	2004-5-24	
1	FRAME	STEEL STRIP	1	Ni PLATED			CHK'D	FANGYING	2004-5-24	
NO.	PARTS	MATERIALS	Q'TY	FINISH	ALL MATERIALS MUST BE COMPLIANT TO ROHS	APPD.	KANGXINAN	2004-5-24		